

MS series

Proportional compact hand grip controllers •
non-contacting Hall effect technology



DISTINCTIVE FEATURES

One, two or three axis

Analog output

10 million lifecycles

CAN bus J1939 and CANopen outputs available

Redundant outputs available



ENVIRONMENTAL SPECIFICATIONS

- Operating Temperature: -25 °C to +70 °C (-13 °F to +158 °F)
- Storage Temperature: -40 °C to +70 °C (-40 °F to +158 °F)
- Sealing: IP67 Above panel (subject to final specifications)
- EMC Immunity Level: EN61000-4-3:2006
- EMC Emissions Level: EN61000-4-8: 2009
- ESD: EN61000-4-2:2008



ELECTRICAL SPECIFICATIONS

- Supply Voltage Range: 5.00VDC \pm 0.250VDC
- Reverse Polarity Max: -10VDC
- Transient Overvoltage Max: 18VDC
- Output Impedance: 6 Ω
- Current Consumption Max: 10mA max per axis
- Return to Center Voltage (no load): \pm 200mV



MECHANICAL SPECIFICATIONS (X & Y AXIS)

- Operating Force: 7.5N (1.70lbf)
- Maximum Vertical Load: 444.8N (100lbf)
- Maximum Horizontal Load: 667N (150lbf)
- Mechanical Angle of Movement: 40° X & Y axis (subject to limiter plate)
- Expected Life: 10 million lifecycles
- Lever Action (centering): Spring

The company reserves the right to change specifications without notice.



MS series

Proportional compact hand grip controllers • non-contacting Hall effect technology



MECHANICAL SPECIFICATIONS (Z AXIS)

- Operating Torque: 0.25Nm (2.21lbf in)
- Break out Torque: 0.15Nm (1.33lbf in)
- Maximum Allowable Torque: 4.50Nm (39.83lbf in)
- Mechanical Angle of Movement: 68°
- Expected Life: 1 million lifecycles



MATERIALS

- Body: Glass Filled Nylon
- Boot: Silicone
- Handles: Glass Filled Nylon



MOUNTING

PANEL CUT-OUT

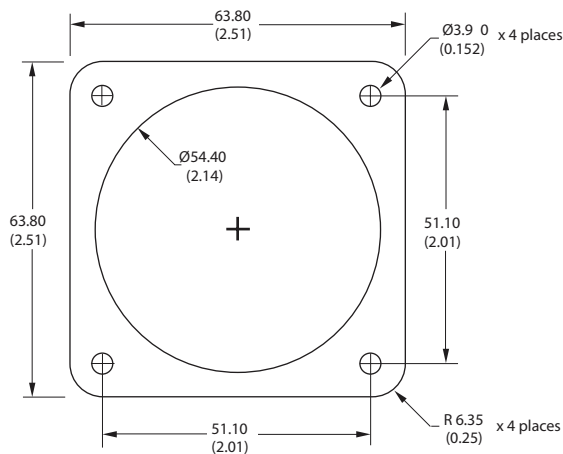

AXIS ORIENTATION

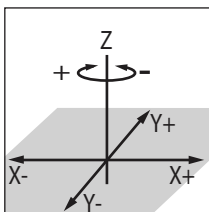

- Standard configurations feature a rubber grommet as indicated in the above drawings
- An optional plastic strain relief is available and will increase under panel mounting depth by 19.05 (0.75).
- Actual strain relief position may vary.



TERMINATION

The MS series is fitted with a 18" ±0.5" AWG22 wire harness. Further non-standard connectors and cable options are available upon request.

WIRE COLOR	SIGNAL
RED	5 VDC for analog outputs within voltage range: 0 VDC to 5 VDC. 7 VDC to 35 VDC for voltage regulator options.
BLACK	Ground
BLUE	X axis data
YELLOW	Y axis data
GREEN	Z axis data
BLUE / WHITE	Redundant X axis
YELLOW / BLACK	Redundant Y axis
GREEN / BLACK	Redundant Z axis
ORANGE	Button 1
VIOLET	Button 2
GREY	Button 3
BROWN	Button 4

Proportional compact hand grip controllers • non contacting Hall effect technology



CAN J1939 INTERFACE SPECIFICATIONS

The MS Series utilizes redundant Hall effect sensors to measure the primary X and Y axis. The CAN controller support various button configurations as well as proportional thumbwheels and mini-joysticks for additional axis data. All axis and button data are delivered on a CAN 2.0B compliant physical interface. Two additional signals allow configuration of the controller Source Address. Controller messages are delivered per the SAE J1939-71 message protocol.

CAN 2.0B INTERFACE PARAMETERS

- Baud rate: 250 KHz
- Transmission repetition rate: 50ms
- BJMI/EJMI interval time: 20ms
- Terminating resistor: No (available by special request to factory)
- The MS series joystick configured with CAN bus outputs are configured with 22 AWG 18" ± 1.0" wire harness as standard. An optional Deutsch DTM04-6P connector may be specified from the configuration guide.
- Optional connection to Deutsch DTM04-6P connector:

Pin	Color	Function
1	White	CAN Lo
2	Green	CAN Hi
3	Blue	Source Address SEL 1
4	Orange	Source Address SEL 0
5	Black	Ground
6	Red	6 - 35 VDC

Note 1: Alternate source addresses can be configured by grounding of the blue and/or orange wires.

- Source address= 0x10: ORANGE= floating , BLUE= floating (default)
- Source address= 0x20: ORANGE= floating, BLUE= grounded
- Source address= 0x30: ORANGE= grounded, BLUE= floating
- Source address= 0x40: ORANGE= grounded, BLUE= grounded

CAN MESSAGE PROTOCOL

- Primary Axis and button data on Basic Joystick Message (BJM1):
 - Priority: 3
 - Base PGN: 0xFDD6
 - Source address: 0x10¹
 - Data field: 8 bytes
- Redundant Axis data on Extended Joystick Message (EJMI):
 - Priority: 3
 - Base PGN: 0xFDD7
 - Source address: 0x10¹
 - Data field: 8 bytes
- Additional thumbwheels and mini-joysticks data on Extended Joystick Message 2 (EJM2):
 - Priority: 3
 - Base PGN: 0xFDD9
 - Source address: 0x10¹
 - Data field : 8 bytes

BJM1 DATA FIELD STRUCTURE:

START POSITION (BYTE/BIT)	LENGTH (BITS)	FUNCTION
1/1	2	Primary X-axis neutral position status
1/3	2	Primary X-axis left position status
1/5	2	Primary X-axis right position status
1/7 to 2/8	10	Primary X-axis position data
3/1	2	Primary Y-axis neutral position status
3/3	2	Primary Y-axis down position status
3/5	2	Primary Y-axis up position status
3/7 to 4/8	10	Primary Y-axis position data
6/1	2	Button 4 status
6/3	2	Button 3 status
6/5	2	Button 2 status
6/7	2	Button 1 status
7/1	2	Button 8 status (Paddle if 6 button configuration) ²
7/3	2	Button 7 status (Trigger if 6 button configuration) ²
7/5	2	Button 6 status
7/7	2	Button 5 status
8/5	2	Button 10 status (Paddle if 8 button configuration) ²

Note 2: If configured with no buttons, trigger and/or paddle would be positioned in Button n+1 and Button n+2.

MS series

Proportional compact hand grip controllers • non-contacting Hall effect technology



CAN J1939 INTERFACE SPECIFICATIONS (CONTINUED)

EJM1 DATA FIELD STRUCTURE:

START POSITION (BYTE/BIT)	LENGTH (BITS)	FUNCTION
1/1	2	Redundant X-axis neutral position status
1/3	2	Redundant X-axis left position status
1/5	2	Redundant X-axis right position status
1/7 to 2/8	10	Redundant X-axis position data
3/1	2	Redundant Y-axis neutral position status
3/3	2	Redundant Y-axis down position status
3/5	2	Redundant Y-axis up position status
3/7 to 4/8	10	Redundant Y-axis position data

EJM2 DATA FIELD STRUCTURE:

START POSITION (BYTE/BIT)	LENGTH (BITS)	FUNCTION
1/1	2	A-axis neutral position status
1/3	2	A-axis left position status
1/5	2	A-axis right position status
1/7 to 2/8	10	A-axis position data
3/1	2	B-axis neutral position status
3/3	2	B-axis left position status
3/5	2	B-axis right position status
3/7 to 4/8	10	B-axis position data
5/1	2	C-axis neutral position status
5/3	2	C-axis left position status
5/5	2	C-axis right position status
5/7 to 6/8	10	C-axis position data



USB SPECIFICATIONS

- Supply Voltage Range: 5.00 VDC
- Maximum current: 70 mA
- USB version: 2.0

USB GAME CONTROLLER

Featuring USB 2.0 HID compliant interface, APEM's USB joysticks are recognized as standard HID "game controller" devices. Adhering to the HID specification, APEM's USB joysticks are plug-and-play with most versions of Windows. Joystick button and axis assignments are dependent upon the controlled application.

Features

- USB 2.0 HID compliant "game controller" device
- Easy to install and operate
- Functions determined by controlled application
- 12-bit (0 to 4095) axis resolution

Termination (supplied cable)

- USB Male Type A Connector: (84" +/-1") - overmolded cable - Male Type A USB connector (option 0-U)

USB CURSOR EMULATION

The Cursor Emulation option converts multi-axis joystick output into a mouse or cursor control device. The Cursor Emulation option is ideal for vehicle applications subjected to dirt and high vibration which makes operating a traditional cursor control device difficult. Cursor emulation is only compatible with Window OS.

Features

- HID compliant "mouse" device

Termination (supplied cable)

- (84" +/- 1") – overmolded cable – Male Type A USB connector

Proportional compact hand grip controllers • non contacting Hall effect technology



USB SPECIFICATIONS (CONTINUED)

SUPPORTED OPERATING SYSTEMS: USB GAME CONTROLLER AND CURSOR EMULATION

Windows Operating System

- Windows 7
- Windows 8.1
- Windows 10

Linux Operating System

APEM's USB joysticks are compatible with Linux, although system compatibility is not guaranteed. The user is responsible for verifying specific Linux OS compatibility.

Custom Firmware

Custom configurations and firmware is available upon request. Available options include:

- 8-bit axis resolution
- 10-bit axis resolution
- Signed bit axis resolution
- Custom USB product name



VOLTAGE REGULATOR SPECIFICATIONS

The Voltage Regulator allows APEM's Hall effect joysticks to operate with a range of supply voltages..

Voltage Regulator - Unipolar

- Supply Voltage Range: 8-35 VDC
- Output Voltage Range: see output options
- Maximum Current: 90 mA

Voltage Regulator - Bipolar

- Supply Voltage Range: 11-35 VDC
- Output Voltage Range: ± 10 VDC
- Maximum Current: 90 mA

Termination (flying leads)

- 22 AWG 18" +/- 1"

MS series

Proportional compact hand grip controllers • non-contacting Hall effect technology



BUILD YOUR PART NUMBER

MS					
SERIES	HANDLE	FRONT BUTTONS	TOP BUTTONS	SIDE BUTTONS	LIMITER PLATE
	<ul style="list-style-type: none"> 10 Ball tip 42 Stock grip 31 Short stock grip 23 Low profile¹ (2 axis) 24 Low profile¹ (3 axis) 54 Low profile¹ square front (2 axis) 55 Low profile¹ square front (3 axis) 	<ul style="list-style-type: none"> N None O One W Two 	<ul style="list-style-type: none"> 0 None 1 One 2 Two R Rocker 	<ul style="list-style-type: none"> 0 None U One upper position L One lower position F Two D Operator Presence Paddle 	<ul style="list-style-type: none"> S Square R Round X Slotted horizontal Y Slotted vertical P Plus D Diamond G Guided feel - square H Guided feel - round
SPRING TENSION	OUTPUT OPTIONS		ADDITIONAL OPTIONS		
<ul style="list-style-type: none"> 00 Standard 	<ul style="list-style-type: none"> 0 0V to 5V (rail to rail) 1 0.5V to 4.5V 2 0.25V to 4.75V 3 1V to 4V 4 0V to 5V Sensor 1 0V to 5V Sensor 2 5 0.5V to 4.5V Sensor 1 0.5V to 4.5V Sensor 2 	<ul style="list-style-type: none"> 6 0.25V to 4.75V Sensor 1 0.25V to 4.75V Sensor 2 7 1V to 4V Sensor 1 1V to 4V Sensor 2 8 0V to 5V Sensor 1 5V to 0V Sensor 2 9 0.5V to 4.5V Sensor 1 4.5V to 0.5V Sensor 2 10 0.25V to 4.75V Sensor 1 4.75V to 0.25V Sensor 2 	<ul style="list-style-type: none"> 11 1V to 4V Sensor 1 4V to 1V Sensor 2 0-U USB 1-J Cursor emulation 2-C CAN bus J1939 3-C CANopen 	<ul style="list-style-type: none"> V Voltage regulator E Environmental sealing * D Deutsch DTM04-6P connector. ¹ 	

* Above panel sealing up to IP67 (dependant upon handle configuration)

¹ = 22AWG, 18" +/- 1" wire harness terminated to a Deutsch DTM04-6P connector. Recommended for CAN bus output options: 2-C, 3-C. Consult factory for additional output options.



ABOUT THIS SERIES



Mounting accessories : Standard hardware includes: 4 screws (6-32x7/8) Phil.

Proportional compact hand grip controllers • non contacting Hall effect technology

HANDLE 10 - BALL TIP

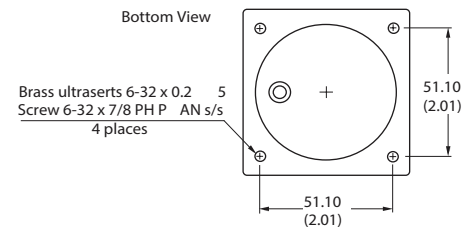
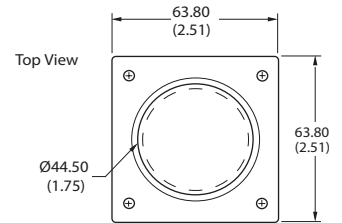
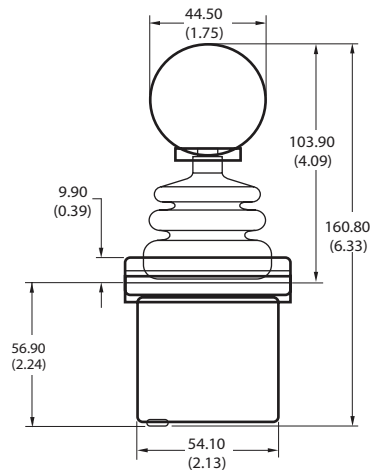

HANDLE 42 - STOCK GRIP

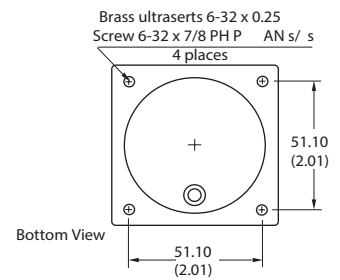
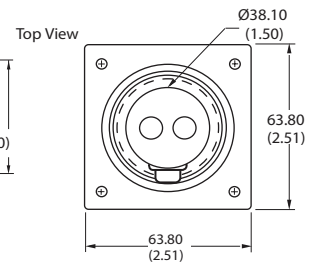
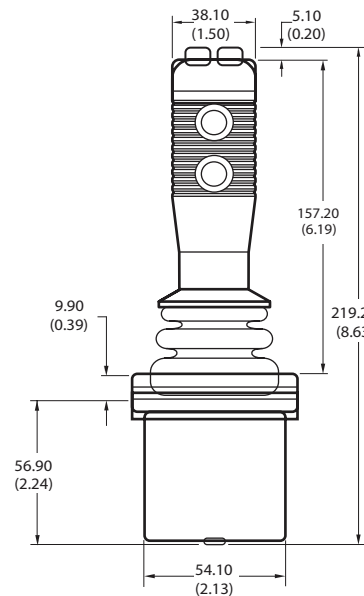

HANDLE 31 - SHORT STOCK GRIP

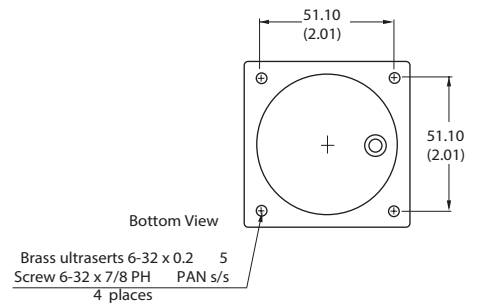
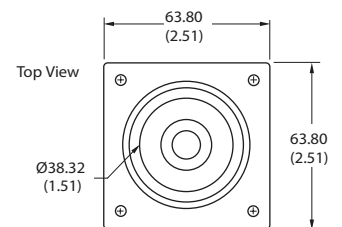
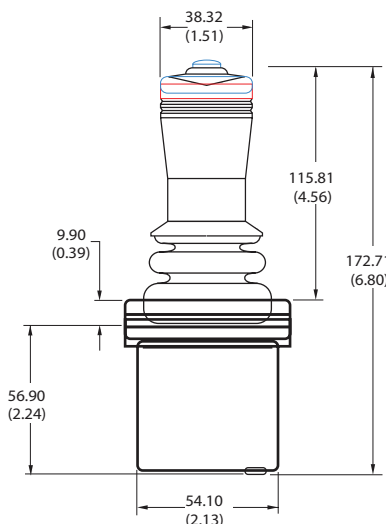

MS series

Proportional compact hand grip controllers • non-contacting Hall effect technology

HANDLE 23, 24 - LOW PROFILE (2 & 3 AXIS)

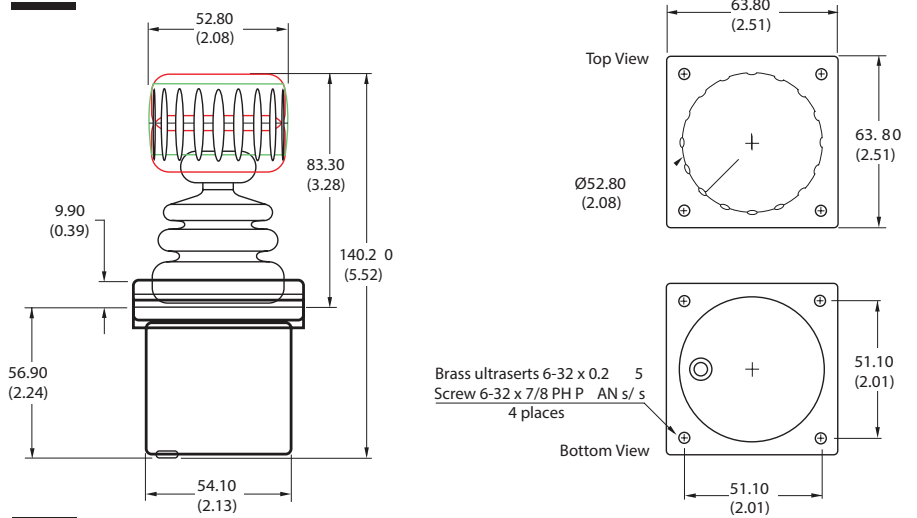

HANDLE 54, 55 - LOW PROFILE SQUARE FRONT (2 & 3 AXIS)

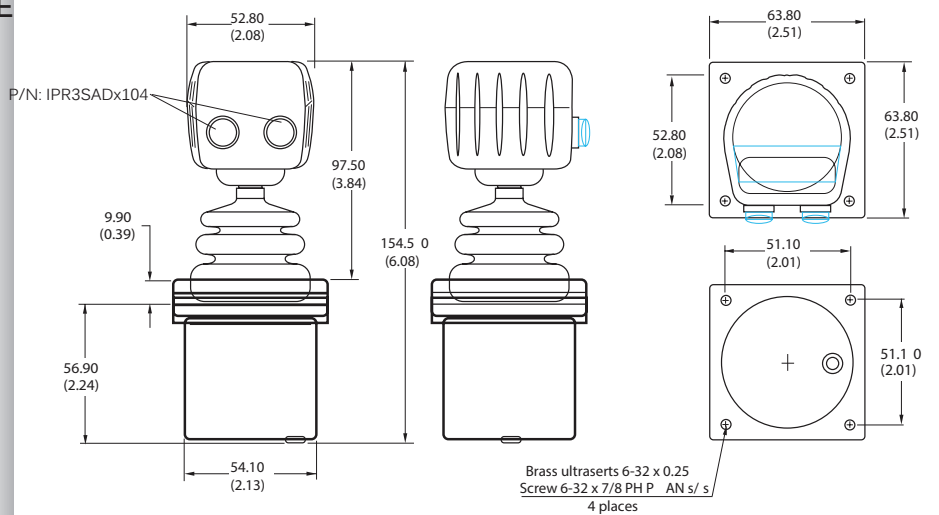

HANDLE OPTIONS

STOCK GRIP HANDLE (1)

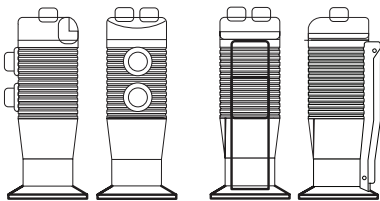

Top & Side Buttons

Operator Presence Paddle

SHORT STOCK GRIP HANDLE (2)

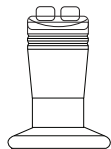

LOW PROFILE SQUARE FRONT (3)

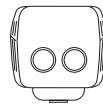

Front Buttons

P/N: IPR3SADx104

AVAILABLE BUTTON COLORS

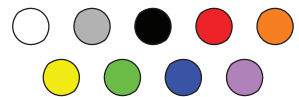

White, Gray, Black, Red (4), Orange, Yellow, Green, Blue, Purple

1. The maximum possible configuration for the Stock Grip handle is up to 2 Top Buttons and 2 Side Buttons. A handle with an Operator Presence Paddle can have 2 Top Buttons, but no Side Buttons.
2. The maximum possible configuration for the Short Stock Grip handle is up to 2 Top Buttons. It is not possible with Operator Presence Paddle, Index Trigger, or Side Buttons.
3. The maximum possible configuration for the Low Profile Square Front handle is up to 2 Front Buttons. It is not possible with Operator Presence Paddle, Index Trigger, or Top Buttons.
4. If unspecified, the pushbuttons will have snap action momentary switches with red button caps.